

Protect fence pipe lamp specification

Features

- Input voltage: 12 VAC (can suit customer actual voltage demand)
- Input voltage frequency: 50~60 Hz
- Power is consumed (contain drive circuit): Is smaller than 15W
- Use environment / operating temperature: -45°C~85°C (outdoor use)
- Protective device: Have instant overvoltage to protect
- LED puts in order: According to lampshade and give out light uniformity adopt put in order specially
- Drive circuit design: Have the intelligent circuit sense monitoring of microcomputer; do not operate function since a LED fault affects; Have to prevent that strike of thunderbolt is dampproof and insulation design
- Product adopts polyester housing, fight impact, fight ageing, guard against ultraviolet ray
- LED Protect fence pipe lamp is a kind of type of environmental protection decorate the decorations of exciter lamp, have energy efficient, Long life with zero maintenance, brightness higher characteristic ;
have various color; pursue, the changes such as running water, color much shape and colour are bright-colored, have soft lamplight, do not have frequency to dodge, do not have dazzle
- Waterproof grade: IP67

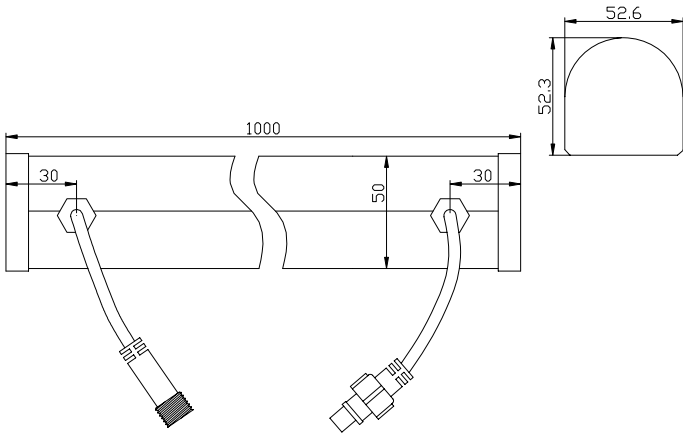

Applications

- Various bridge, road, mansion, mountain villa etc; outline is sketched out and decorates at night

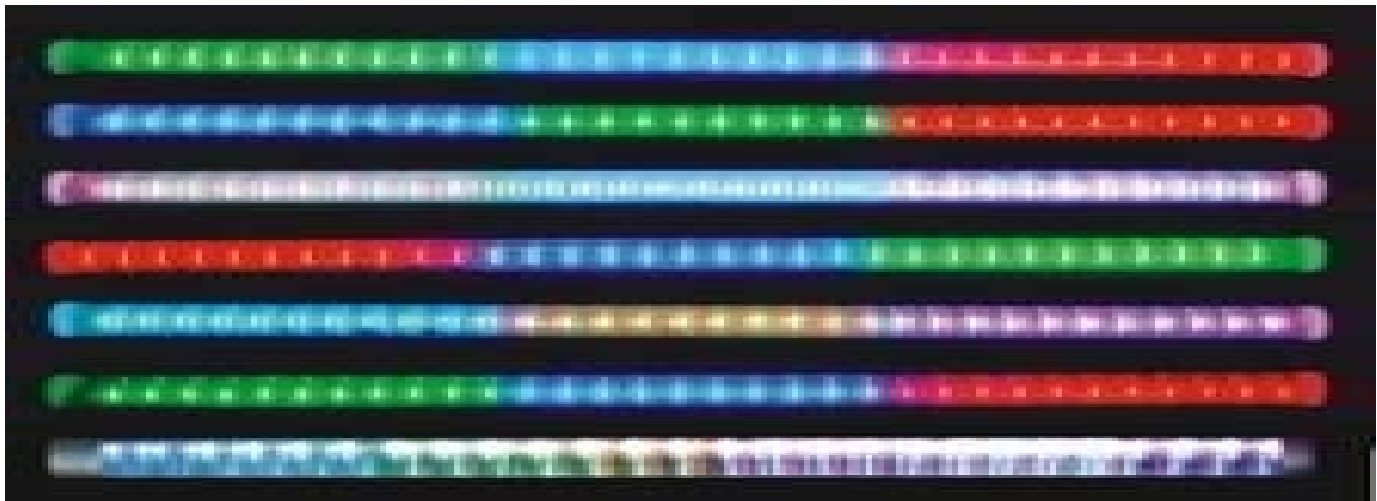

Part No.	Size	Voltage	Current	Power	Color	Housing	Illuminance	LED QTY
ML-ZTM05R-LH1	1000×50×50mm	12 VAC	1 A	12 W	Red	PC	52 Lux	144 PCS
ML-ZTM05Y-LH1	1000×50×50mm	12 VAC	1 A	12 W	Yellow	PC	77 Lux	144 PCS
ML-ZTM05G-LH1	1000×50×50mm	12 VAC	1 A	12 W	Green	PC	92 Lux	144 PCS
ML-ZTM05C-LH1	1000×50×50mm	12 VAC	1 A	12 W	Cyan	PC	77 Lux	144 PCS
ML-ZTM05B-LH1	1000×50×50mm	12 VAC	1 A	12 W	Blue	PC	45 Lux	144 PCS
ML-ZTM05P-LH1	1000×50×50mm	12 VAC	1 A	12 W	Purple	PC	52 Lux	144 PCS
ML-ZTM05W-LH1	1000×50×50mm	12 VAC	1 A	12 W	White	PC	114 Lux	144 PCS